

# Instruction Manual For Hydraulic Log Splitter

## LS6T

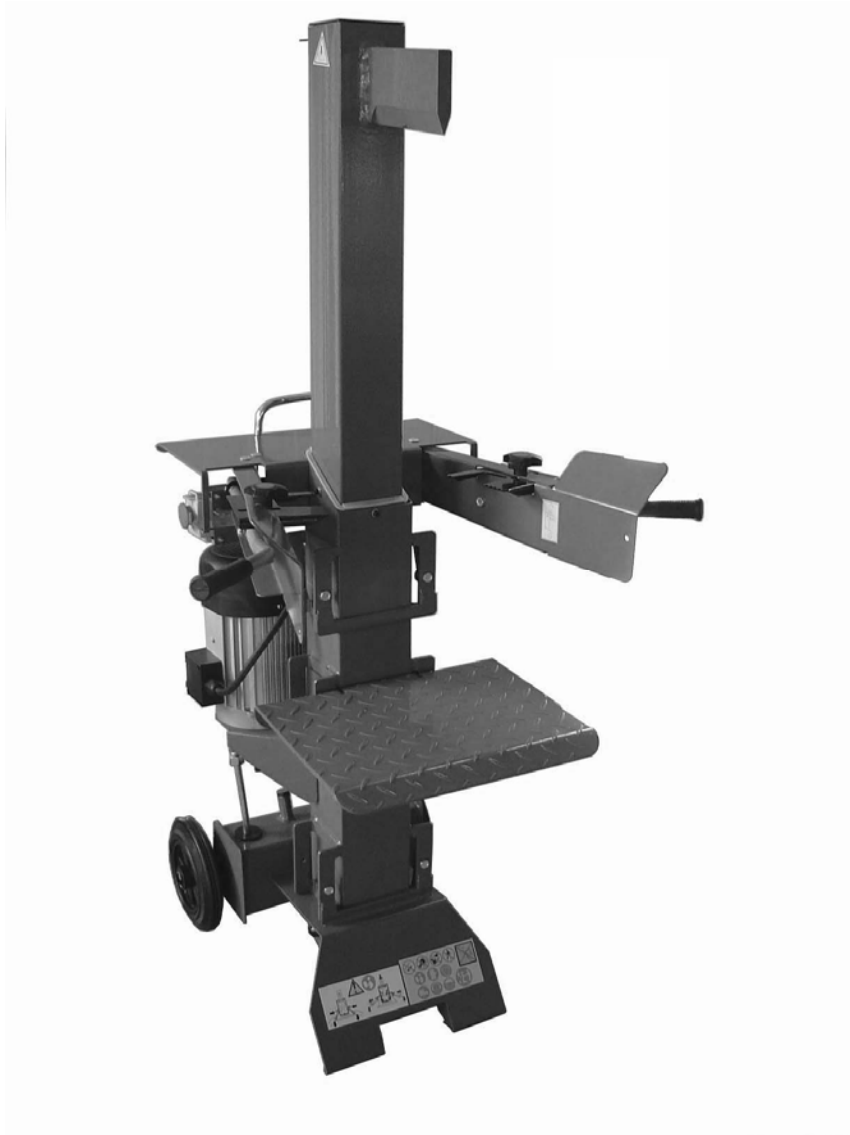

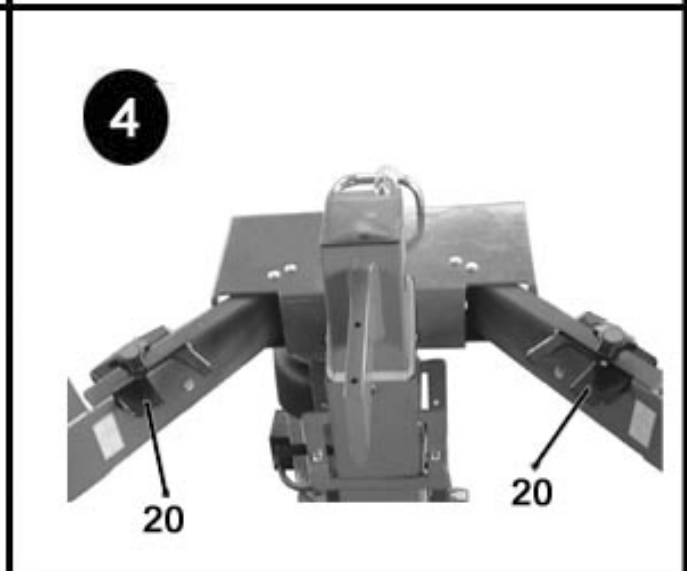
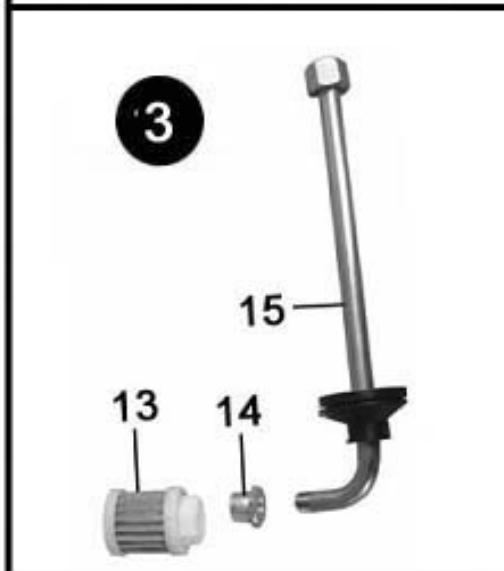
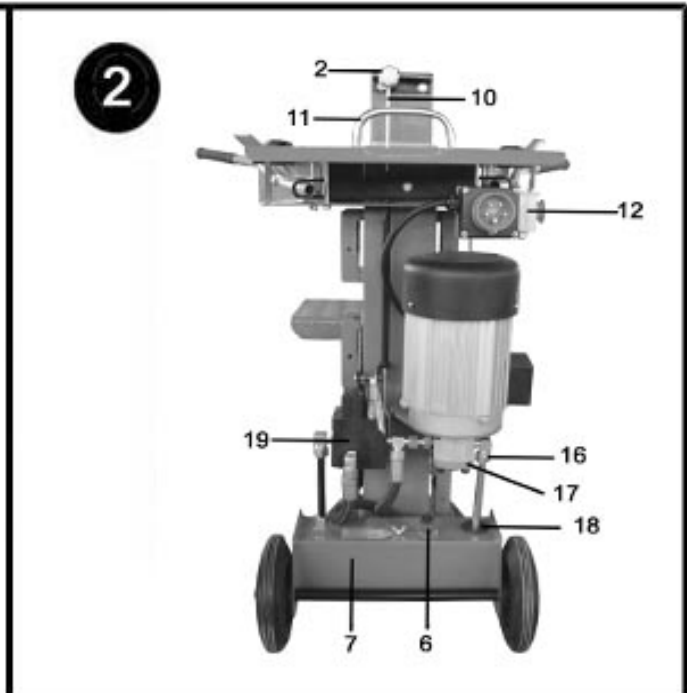
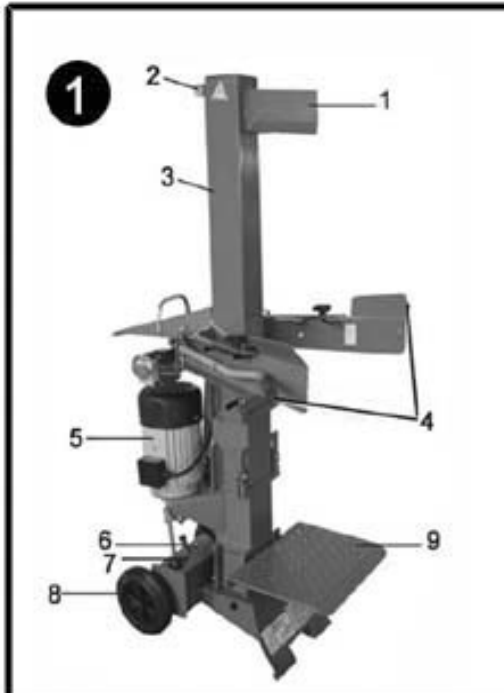

- 1. Splitting wedge
- 2. Ram Travel adjusting knob
- 3. square pipe 100x100(inner)
- 4. operating handle (Control Lever)
- 5. motor
- 6. oil cap
- 7. oil tank
- 8. wheel
- 9. work table
- 10. Ram Travel Adjusting Rod

- 11. Moving handle
- 12. switch
- 13/14. oil filter
- 15. oil circuit steel pipe assembly
- 16. G3/8"xM18 straight angle curly head
- 17. Pump
- 18. sealing rubber
- 19. Valve
- 20. Adjustable log holder

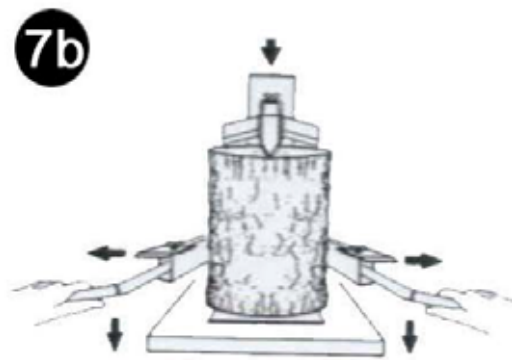
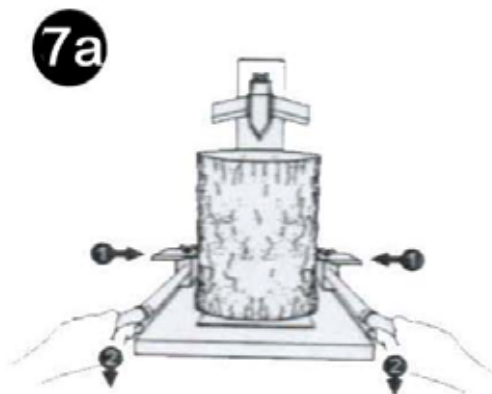
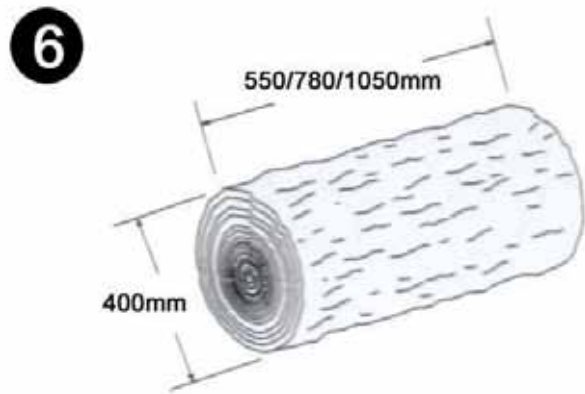
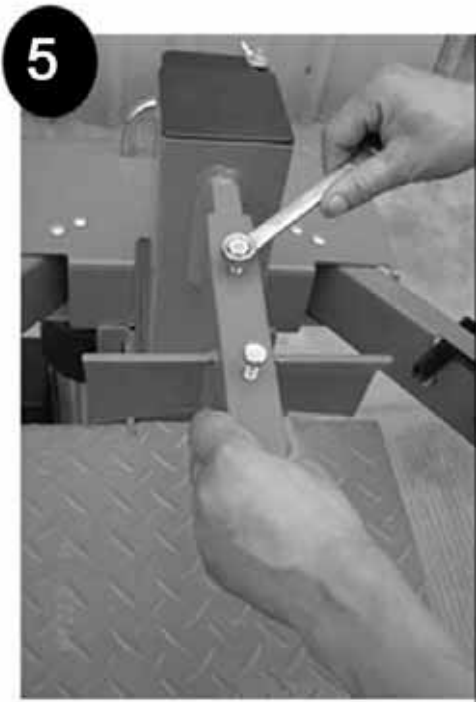

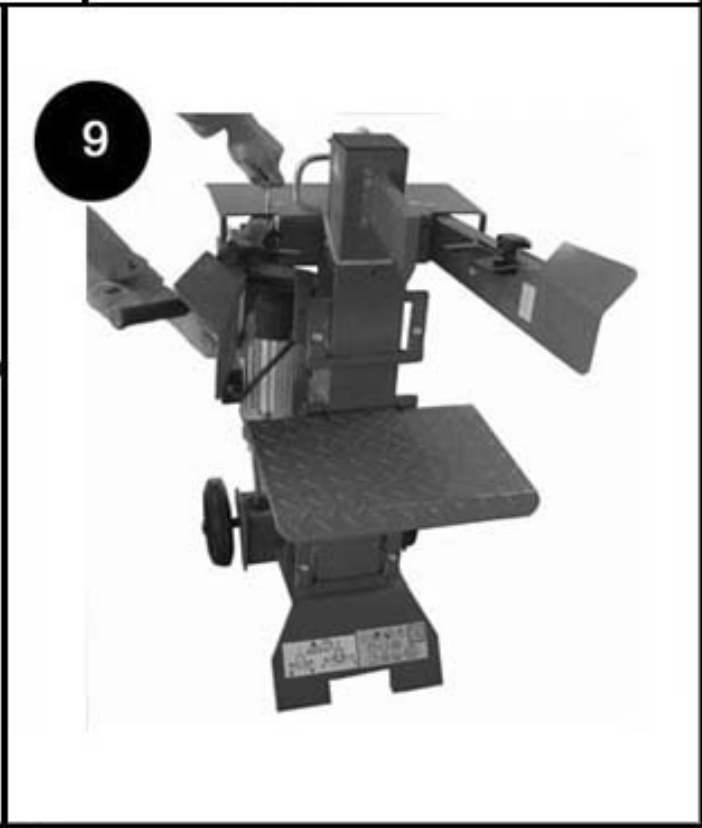
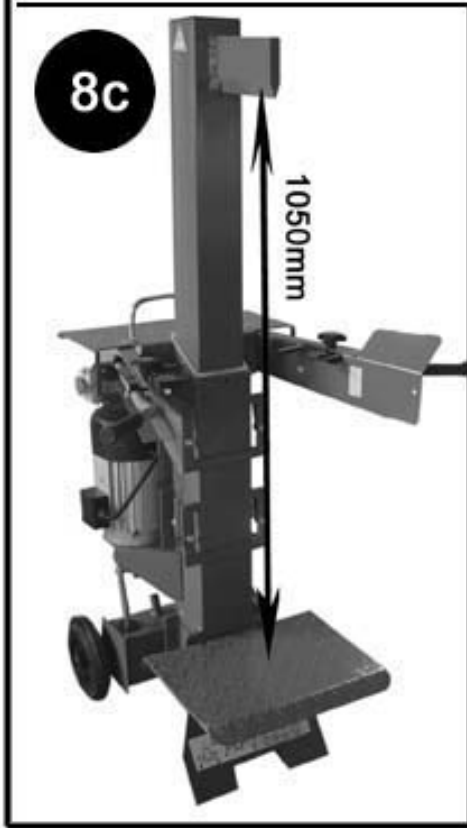
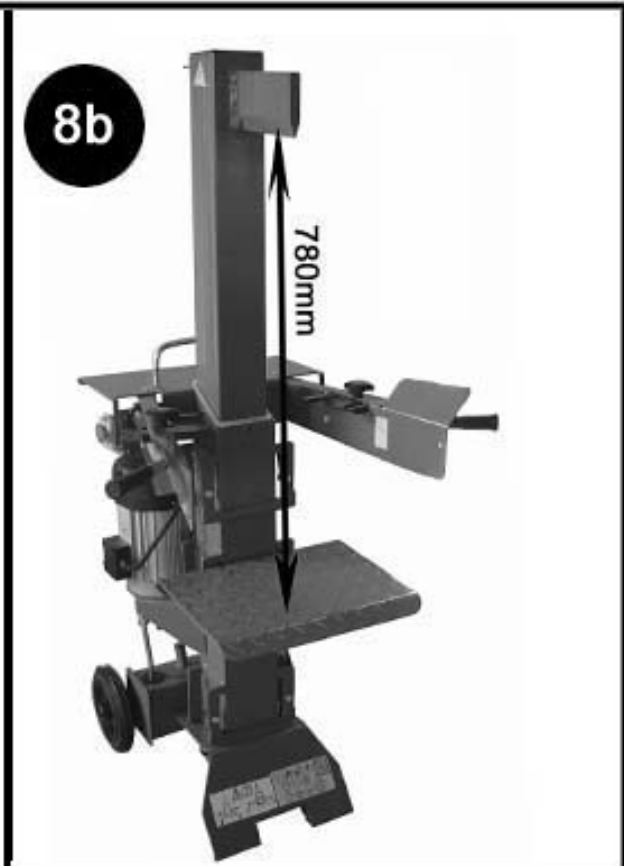
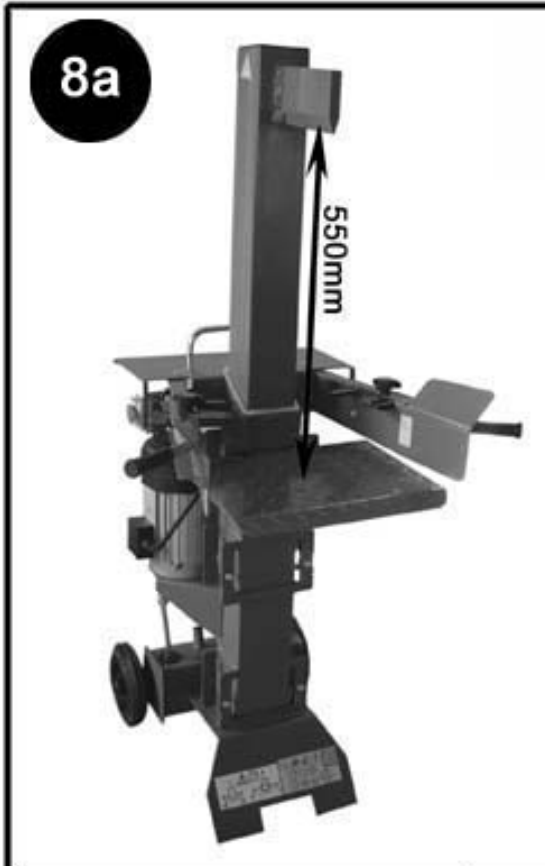

## 2. Safety instructions



Do not install, repair , clean or handle the log splitter when the machine is still running and Without having securely clamped the wedge.

Severe personal injury or machine damages can result form not complying with operation .assembly.

maintenance and repair instructions contained in this manual.

Allow only adults to operate/maintain the log splitter after they have received sufficient training and have made themselves familiar with the machine .

Make sure that full compliance is assured at all times with the general safety and health rules on the workplace as well as the applicable local traffic rules.

No one under the age of 18 should be allowed to operate the log splitter .However. young people in age of 16 or slightly more may work on the machine providing that they received adequate training ,they carry all due personal protection safeties and that an adult supervisor keeps standing nearby.

Machine instability can result in injury or severe damages,

To ensure stability during operation make sure to choose a flat , dry floor free from any tall grass , brush or other interferences.

To avoid tripping , do not leave tools, logs ,or other components laying around in the work area .Avoid slippery floor conditions by eventually scattering saw dust or wood pellets.

### Following precautions must be taken at all times

**-NEVER** use your log splitter at night or without sufficient illumination.

**-NEVER** operate your log splitter on slippery ,wet ,muddy , or icy surfaces.

**-NEVER** let electrical works be carried out by unskilled staff.

**-NEVER** operate the machine without wearing protective shoes , tight-fitting gloves and apparels

**-NEVER** remove from your log splitter the safety tools and devices mounted on the machine by the manufacturer.



**-NEVER** leave the machine unattended with the running motor .

Assure full compliance with all applicable and traffic and safety rules in your country and especially with applicable health and safety provisions on the workplace.

Personal protection must be assured by wearing safety shoes and gloves ,tight-fitting apparels and goggles during splitting  
Make sure to select a suitable place with sufficient clearance for proper operation of the machine as well as or safe handling of the split logs and eventual ancillary tools and equipment.

**To be operated by one person only !**

### **PREVENT FIRES**

Do not smoke or have open flames when operating or refilling the log splitter. Never operate the log splitter near a flame or spark. Oil is flammable and can exploded.

### **PROTECT YOUR HANDS**

When the ram of the log splitter is in the return mode, keep your hands off the machine. Keep your hands away from splits and cracks which open in the log. They may close suddenly and crush or amputate your hands. Do not remove jammed logs with your hands.

### **PROTECT YOUR EYES AND FACE**

Any log splitter may throw foreign objects into the eyes. This can cause permanent eye damage. Always wear safety goggles. Everyday eyeglasses have only impact resistant lenses. They are not safety glasses.



## **2.1 Mandatory use and application**

The log splitter is strictly designed for one-man operation ,Never allow more than one person approach and work on the machine at the same time .

This splitter is conceived for splitter short and long logs for firewood preparation only BEWARE; no cross. grain splitting is permitted . Always split grain-wise.

When placing the log on the log splitting make sure that the chunk rests entirely and safely on the riffle-plate table

Any other use or splitting method is considered by the manufacturer as misuse. In case of misuse the manufacturer will be held entirely responsible.

Please make sure to comply with these set-up .operation and maintenance/repair instructions in order to avoid happening of any injury or dangerous condition .

**BEWARE: this unit has a log capacity of min 70 mm and max 400 mm diameter.**

**Danger! Keep clear of moving parts!**

## **2.2 APPLICATION CONDITIONS**

This log splitter is designed for operating under ambient temperatures between +5°C and 40°C and for installation at altitudes no more than 1000m above M.S.L. The surrounding humidity should less than 50% at 40°C. It can be stored or transported under ambient temperatures between -25°C and 55°C.

## **2.3**

Never dismantle and reassemble the log splitter by yourself unless you are a professional engineer. Otherwise, the self-assembling may lead to some dangers as below:

- (1)Oil leak (3)motor & pump damage  
(2)No pressure (4)pressure is too big for cylinder endurance etc.

## **3. Operating instructions**

### **3.1 Hand-guards assembly**

Uncrate and assemble the special hand-guards on the hand control levers before first use and installation.

The two hand control levers must be fixed to the two hand guards , that means the hand levers and hand guards must be assembled as a whole with screws, then install them together to the machine for operation. Make sure to tight all screws after complete guard assembly.

### **3.2 Electrical specs**

With 400 Volt/50Hz motor, the log splitter should be connected to standard 400V ± 10%/50Hz.

Connect the 400VAC motor using a power cable in a minimum

section of 1.5mm<sup>2</sup>(cable specs 3×1.5).Power feeding is performed via a control switch electrically connected between a power source(plug) and the drive motor.

### **3.3 Hydraulic specs**

The machine is equipped with own hydraulic oil tank located inside the base-stand and is supplied by the manufacture with a first oil fill.

BEWARE: a leaning splitter position during transport may result into oil leakage from the oil plug.

At low ambient temperature the oil in the hydraulic circuit will thicken. In this case, it is recommended to avoid sudden start-up(splitting without warming the motor up)that could result into damages and trouble of the hydraulic system..

To assure trouble free operation of the hydraulic system at low ambient temperature, let the motor run idle and cycle the unit several times till the oil in the hydraulic loop warms up.

Setting of the main control valve is done at manufacturer before shipping. The unit comes to you ready for service so that no other adjustment/installation work is required other than assembly of the hand-guards on the control levers.

### **3.4 Initial check (before operating)**

The log splitter is equipped with safety two-hands mechanical controls designed for the operating to keep both hands free from danger and from infringing the moving ram zone during the entire splitting cycle.

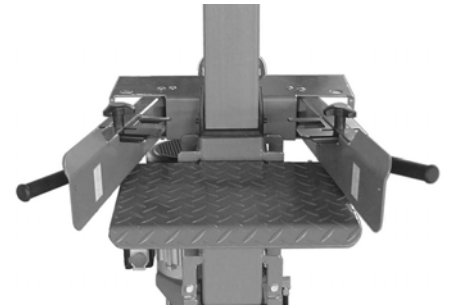

It is strongly recommended to check the operation of the two-hands control every time before a new use.

To do so, engage both hand levers and hold them down at the same time until the ram slides all the way down. If your system is duly set , the wedge stops upon releasing or just one of the two levers while the ram stops completing its up/down stroke at once. On the other hand, the ram must recommence its upwards travel to the initial start position (all the way up) as soon as the other levers is also released.

Make sure that the ram does not travel down when operating only one single lever.

Check that both lever spring back into their normal position when the hand pressure is released

### **3.5 Start-up**

Before first use, make sure that the log splitter is in good conditions and that no visual damages are there.

Check all hydraulic hoses, fittings and coupling and to detect and repair eventual oil leaks.

Make sure that all safeties and protections are duly assembled on the machine. Do not attempt to remove or by pass these safeties!

Make sure the that the log splitter will not be damaged or made unsafe by any operation, lubrication, maintenance, or repair procedures that you choose .Should any trouble or unusual behavior be detected, do not start splitting wood until these have been fixed.

### **3.6 WARNING**

The location you choose for your machine should be flat, dry, and solid. Check around log splitter for hazards. Make sure that the area is free of slippery surfaces and objects to over. Slippery and icy floor conditions must be duly treated to assure solid standing conditions.



Never reach with your hands at pinch points where they can get caught by the traveling wedge!

### 3.7 Ram travel adjustment

The ram travel is factory set the maximum log capacity before shipment .You just need to start the motor and the ram slides automatically up to the maximum travel stroke. Should your chunks be much shorter than your capacity adjustment on the machine it is possible to adjust the ram stroke accordingly Step less ram stroke adjustment is possible at all times .

#### RAM STROKE ADJUSTMENT PROCEDURE:

Let the ram slide down to the desired stroke length and shut the motor off. When you do this make sure to engage one of the control levers in order to prevent the ram from returning back to its upper start position .Now release the wing-nut on the rear grip-handle and pull up the control rod as much as possible .The ram travel is reduced by an equivalent stroke length as the pulled-up rod length Once the rod is pulled sufficiently up to obtain the desired ram stroke .tight the wing-nut back to the original torque Now completing a shorter travel than the original full-stroke .

Later ram travel adjustments to the original full-stroke length can be repeated at all times by simply releasing the wing-nut , pushing the rod backing and tightening the wing-nut again.



**ram travel adjustment**

### 3.8 Table height adjustment

The log splitter table can be hanged-up at three different levels (additional safety pins are available for table fixation on the upper level)Changing of the level can be easily performed without any additional tool or help

TO do this

- remove the safety lock pin o one side.
- now, slightly lift table up and it out towards you .
- slip the table onto the lower level mount ,grip the front rim of the table and slightly lift it up ,and push it down to stop.
- now release grip on the front rim and let the table settle down making sure. That the rear table hooks are well and firmly settle on the mounts(see picture on the side)

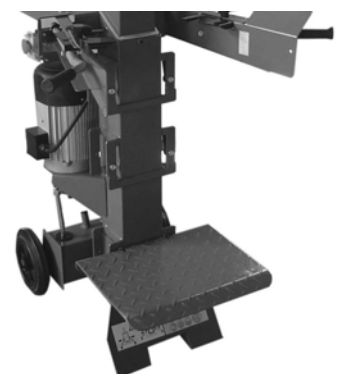

**hanged up table**

### 3.9 Log clamps adjustment

In order to hold the log firmly under the wedge during the entire splitting cycle, use the special log-clamps located on each hand control lever. Both Log clamps are adjustable depending on log diameter and size and in case in order to adjust the clamps position first release the clamp on each side. Once adjusted to the desired position lock the clamps into position by tightening the knob again.



**log clamps**

### 3.10 Operation

Start the motor and switch the splitter on.  
Load a chunk on the table, close the hand control levers until firmly securing the log by means of the clamps located on the levers.  
Now push both levers down at the same time to start the cycle and engage the ram that will immediately start traveling down.  
**DO NOT RELEASE THE CONTROL LEVERS UNTIL THE CYCLE IS COMPLETELY OVER AND THE LOG SPLIT.**

Should any emergency arise and stopping be required, simply set the control levers free from your grip. When doing this, the ram will immediately travel all the way back up.

As soon as the log is completely split, release both control levers and let the ram travel back to start position and be ready for a new cycle.  
Do not attempt to catch the split wood or remove wood sticks from the table by hand until the cylinder rod stops at its maximum travel position.  
Clear the table and remove chips and wood debris from the machine before starting a new cycle.

When loading chunks, make sure that logs sit central and firmly with its saw end on the table. Never place your hands on top of the log when loading the log on the splitter.

Do not split wood chunks with lots of branches, first clean it and remove all branches  
**DANGER**, crooked trunk pieces with green/dry branches may burst under wedge pressure!

Make sure to shut the motor off before leaving the area at work end.

### 3.11 Clearing procedure

Depending on the type of wood being split, it may not always break into two pieces and fall to the ground. If a log sticks to the wedge, place the valve handle in the neutral position (stop the wedge from traveling), switch the splitter off and carefully remove or hammer the log off the wedge.

Allowing the log to remain attached to the wedge when it is fully retracted could lead to possible injury and/or damage to the log splitter.

## 4 Transport

before handing, moving or transporting the splitter make sure to cut the power off(unplug the machine).

This machine is conceived for very ergonomic easy handing thanks to the special wheel arrangement in the rear bottom part of the machine. Before handing the machine around, make sure to tie up the two control handles together to prevent the from swinging out and accidentally injure/damage persons or other equipment standing nearby.

One man can easily handle the machine on side by himself, Handing asset is leaned back on the wheel while the operator firmly holds it with one hand on the handle of cover plate and the other hand on the cover plate above the motor.



“Transport”

## 5.Maintenance instructions



**Do not install, repair, clean or handle the log splitter when the machine is still running and without having securely clamped the wedge**

### 5.1 Daily maintenance

Make maintenance regular part of daily operation. The daily maintenance routine needs to include

- Cleaning of the machine and cleaning of all parts from residual wood debris. chips, dust, bark pieces and eventual other waster.
- Greasing of the sliding pads inside the sliding casing(ram)
- Hydraulic oil check and(in case of leakage)hydraulic hose and fittings check-up to detect eventual oil leaks
- Lubrication of all moving parts

### 5.2 Hydraulic oil

Periodically check the oil level inside the hydraulic oil tank. When doing so, accurately avoid contaminating the tank with dirt, wood chips, saw dust etc...

Make sure that the splitter never runs without oil or with low oil level. When this happens, air is likely to reach inside the hydraulic loop. Failure to maintain due oil or level may cause poor running and irregular splitter operation(very rough, back/forth or up/down motions)as well as major pump damages.

Please schedule your first oil change after approximately 25-30 operation hours and later ones after each 50operation hours or once a year.

The oil drain plug is location on the bottom tank side while the filler cap is on the upper right hand side of the tank.

The hydraulic system is a closed system with oil tank, oil pump and control valve. Check oil level regularly in inspection glass. Low oil levels can damage the oil pump. Oil Level should measure approx. 1—2cm lower than the upper surface of the oil tank. The oil should be completely changed once a year.

- Make sure moving parts stops and the log splitter is unplugged.
- Make sure that no dirt or debris finds its way into the oil tank.
- Collect used oil and responsibly recycle.
- Following an oil change, activate the log splitter a few times without actually splitting

Recommended oil type; DEA HD B46, Shell Tell us 10-46, Esso Nuto H 46

When changing the oil, never let used oil drop down on the ground. rather collect whole of it in a sealed container for due disposal. Oil disposal container be of at least 71 capacity if you are using smaller container make sure to drain the more than one round to avoid splitting old oil out on the ground. Used oil is very polluting and should be disposed in accordance with local rules.

After refilling the tank with new oil, let the splitter cycle three or four times and let the air blow out of the hydraulic loop before closing the cap.

### **5.3 Ram sliding pads**

Should irregular noisy knocks be heard while ram is sliding up and down, grease the plastic sliding pads located inside the sliding ram casing. Preferably use commercial grease available in your country.

Make a trial test before starting to work again. The noisy knock should disappear after greasing.

Should you detect an unusually large gap between sliding ram casing and the guide, sliding pads are likely to be worn out. if so replace them with brand new ones.

## 6. Technical specifications

Log capacity	[mm]	580/770/1050
Min log diameter	[mm]	70
Max log diameter	[mm]	400
Splitting force	[t]	6
Motor power P1	[Kw]	3
Voltage	[V]	400V/50Hz
Rated Current:	[A]	8
Total height(raised ram)	[mm]	1480
Total height(retracted ram)	[mm]	1010
Width	[mm]	470
Length	[mm]	710
Weight	[kgs]	101/109KGS
Tank capacity	[l]	3.2L

The actual splitting force may vary  $\pm 10\%$  of the nominal rating

### 6.1 Noise emissions

Noise emissions were measured in accordance with the European directives for the measurement of noise

missions on the work place .The measurement was performed by external authorized certification bodies in

Compliance with the applicable standards based on applicable rules for agricultural and forestry equipment Noise

Levels were detected and measured at 1600mm height both in front of the and 1000mm far from it ,The detected

Noise level was

**LpA=75dB(A)**

## 6.2 Electric diagram



**BEWARE: only let expert skilled staff do electric repair/maintenance works!**

As for all electric tools and equipment we strongly recommend use a portable residual current device (PRCD), unless you already have a residual current device (RCD) in your house assuring safety and Protection up to max 0.03A nominal fault current.

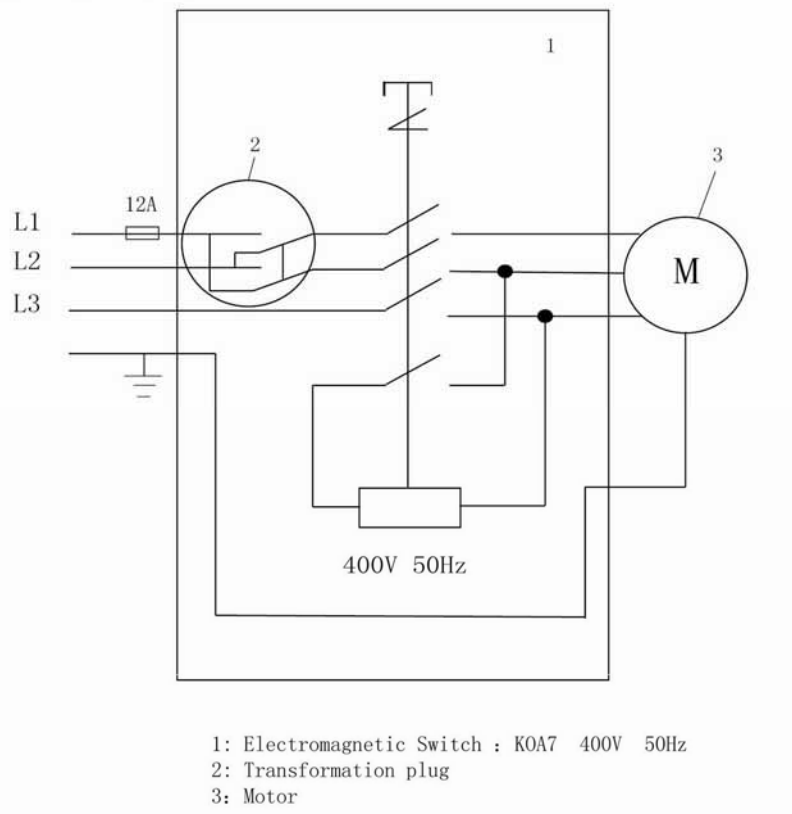

## 7.Risk factors

### 7.1Mechanical dangers

The special two –hands control mechanisms minimizes risks and dangers related to moving parts on the machine

An additional safety provided on the machine in order to prevent working with only one handle while the other

one is being engaged (held down) by some mechanical tool or system .

DO NOTEVERATTEMPT to remove or by-pass the two-hands control Danger operating the splitter without

the safety two-hands control will increase your risk of having your hands pinched during the splitting cycle

Do not remove any other safety and protection device the machine.

WARNING splitting without due safety devices might result into serious injures to the operator or the other person around the workplace .Keep hands and fingers clear at all time Many log-splitting accidents happen on the return portion of the stroke.

### 7.2 Electrical dangers

All machine parts staying under voltage are duly insulated or sealed inside a fixed casing to avoid accidental

contact For safety reasons fixed casings can be only removed using special tools and equipment

WARNING: removing a fixed protection casing when the machine is running or without having priory cut the power

## 8.Trouble shooting chart

Type of malfunction	Possible origins of the problem	Solutions
When the control hands is Pushed down. The wedge Doesn't tower	-Oil level is too low	-Fill oil in
Ram won't retract	See above	See above
Wedge moves slowly or Will not extend completely On normal log	-Oil level is too low -Wrong valve détente -Pump is broken -Cylinder gaskets are damaged	-Fill oil in -Adjust valve -Replace pump -Replace gaskets
Ram stops during Splitting	-Log is too big, cragged or with Lots of branches	-Turn/adjust log position
Hydraulic hoses Heat-up excessively	-oil level too low -Pump is damaged -Wrong valve detente	-Fill oil in -Replace pump -Adjust valve
Motor won't start	-Faulty plug/socket -Faulty/damaged electrical cable	-Replace plug/socket -Replace cable
The electric motor Heats-up excessively	-Cable section is too small _Motor winding is damaged	-Replace cable -Replace winding

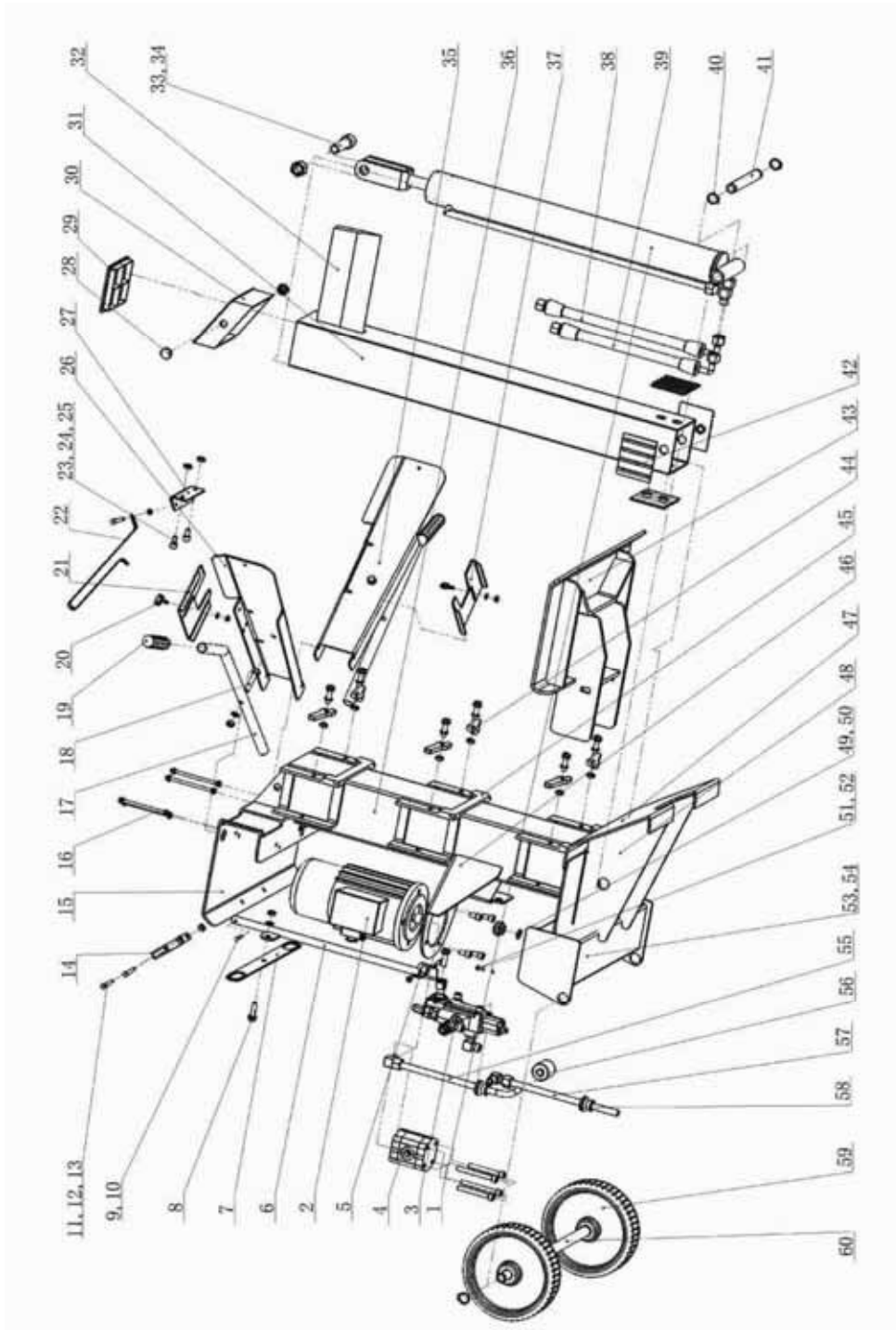



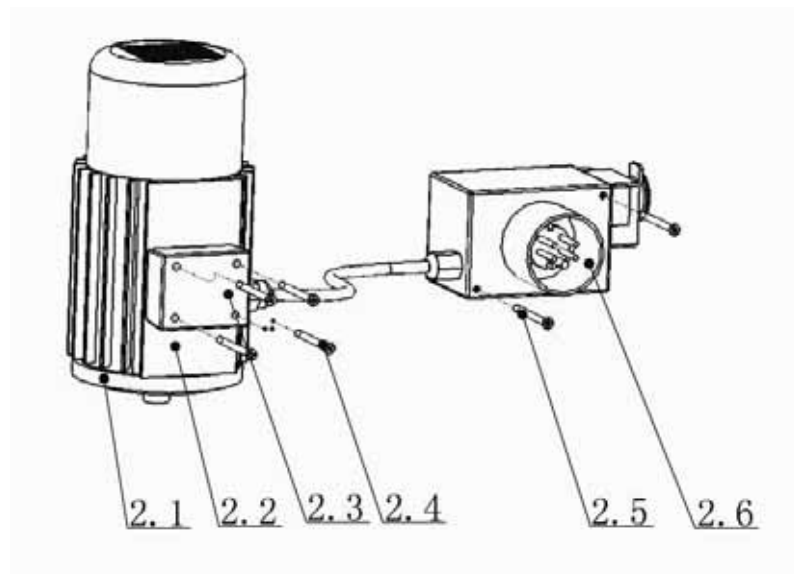
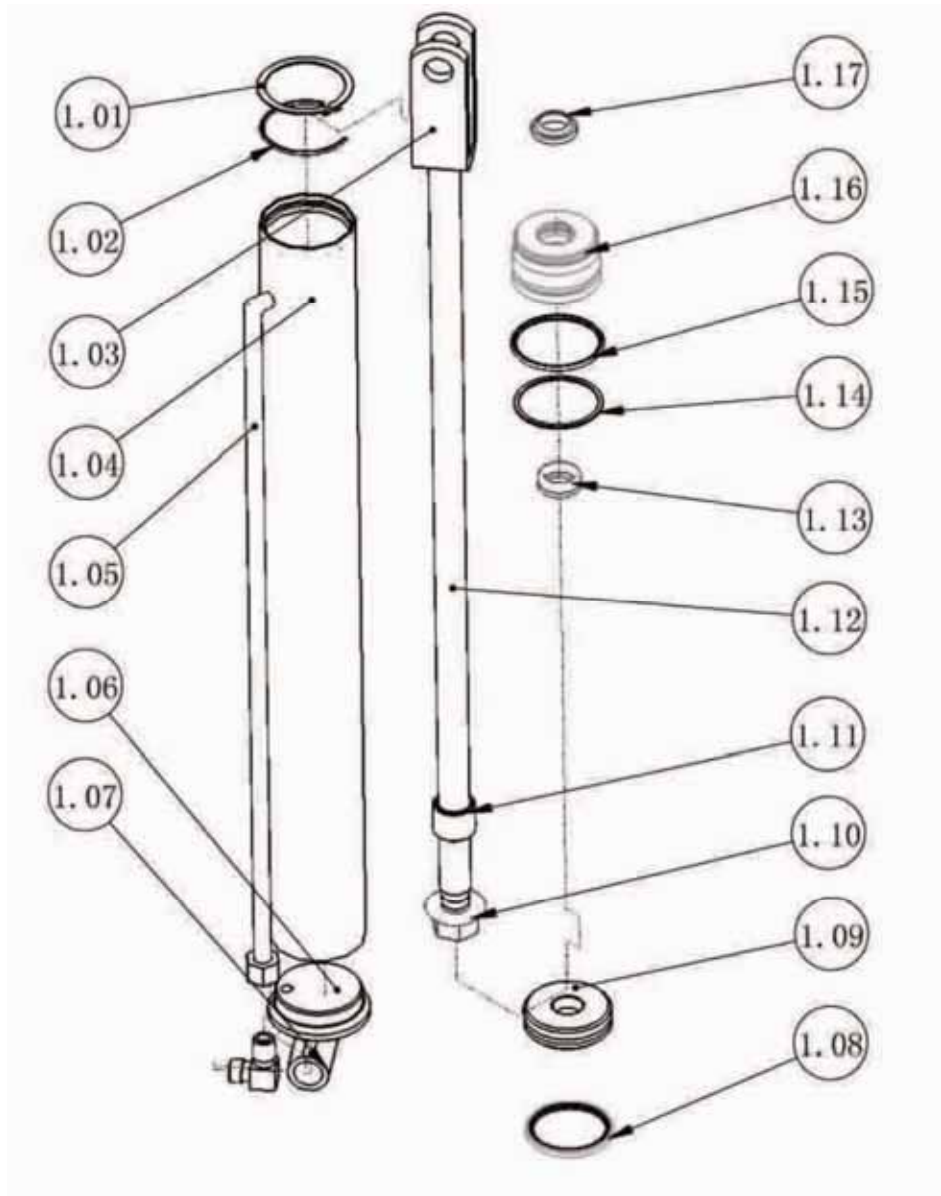

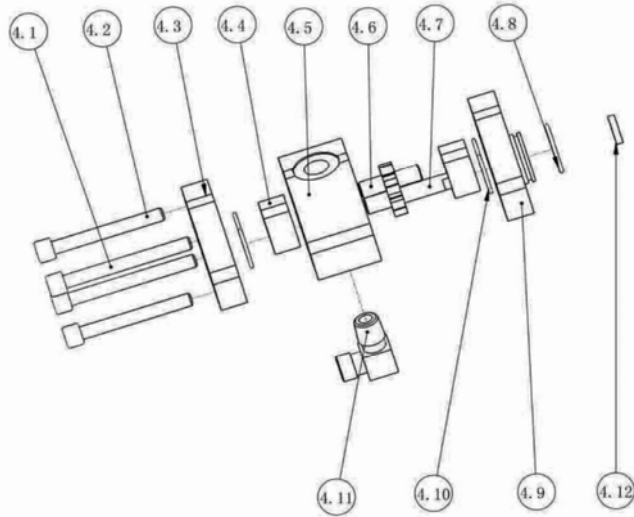
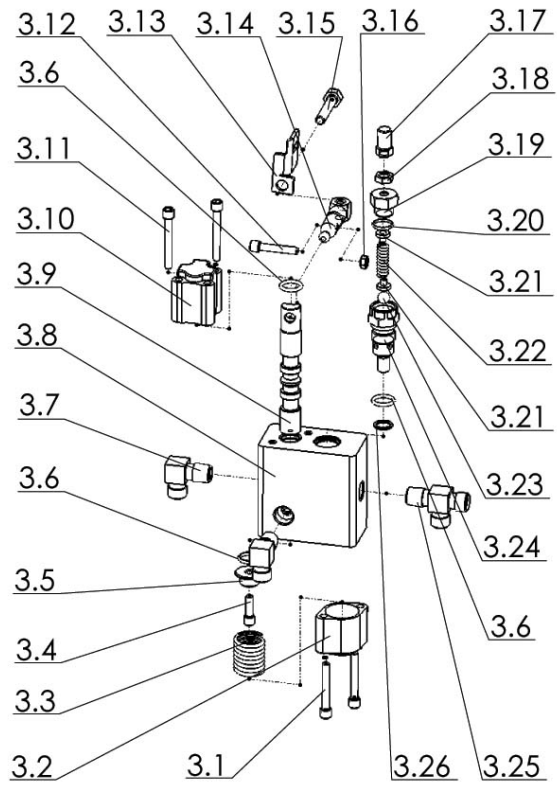

*SPARE PARTS LIST*

No	Name	Quantity	
<b>1</b>	<b>Piston rod assembly</b>		
<b>Piston rod assembly</b>	1.01	Stopper $\phi$ 63	1
	1.02	Stopper $\phi$ 2.6 $\times$ 62	1
	1.03	Connecting plate	1
	1.04	Hydraulic cylinder Column	1
	1.05	Differential oil entering steel pipe assembly	1
	1.06	Cylinder round cover	1
	1.07	Pipe	1
	1.08	Ring $\phi$ 63	1
	1.09	Piston(Moving end)	1
	1.10	M20 $\times$ 1.5 Screw Cap(Anti-loose)	1
	1.11	Bush	1
	1.12	Piston rod	1
	1.13	Seal ring STM-03-22	1
	1.14	Gasket $\phi$ 63 $\times$ 3.5	1
	1.15	"O"ring $\phi$ 63 $\times$ 3.5	1
	1.16	Piston(fixing end)	1
	1.17	Seal ring STM-09-22	1
<b>2</b>	<b>Motor Assembly</b>		
<b>Motor assembly</b>	2.1	Front cover	1
	2.2	Motor	1
	2.3	Wiring box	1
	2.4	Self Tapping Screw M4x40	4
	2.5	Self Tapping Screw M4x50	2
	2.6	Switch(KOA7)	1

## **SPARE PARTS LIST**

<b>NO.</b>	<b>Name</b>	<b>Quantity</b>	
<b>3</b>	<b>Direction exchanging valve assembly</b>		
<b>Direction exchanging valve assembly</b>	<b>3.1</b>	<b>M6x45 inner six angle Bolt</b>	<b>2</b>
	<b>3.2</b>	<b>Valve front cover</b>	<b>1</b>
	<b>3.3</b>	<b>Spring Ø3x45</b>	<b>1</b>
	<b>3.4</b>	<b>M6x15 inner six angle bolt</b>	<b>1</b>
	<b>3.5</b>	<b>Spring bush</b>	<b>1</b>
	<b>3.6</b>	<b>“o” ring Ø18x2.65</b>	<b>1</b>
	<b>3.7</b>	<b>G3/8”xM18 straight angle curly head</b>	<b>1</b>
	<b>3.8</b>	<b>Valve</b>	<b>1</b>
	<b>3.9</b>	<b>Valve rod</b>	<b>1</b>
	<b>3.10</b>	<b>Valve back cover</b>	<b>1</b>
	<b>3.11</b>	<b>M6x50 inner six angle bolt</b>	<b>2</b>
	<b>3.12</b>	<b>M6x45 inner six angle Bolt</b>	<b>1</b>
	<b>3.13</b>	<b>Connecting board</b>	<b>10</b>
	<b>3.14</b>	<b>Round pulling rod</b>	<b>1</b>
	<b>3.15</b>	<b>Six angle bolt M8x25</b>	<b>1</b>
	<b>3.16</b>	<b>M6 stop return screw cap</b>	<b>1</b>
	<b>3.17</b>	<b>Adjusting bolt</b>	<b>1</b>
	<b>3.18</b>	<b>M8 screw cap</b>	<b>1</b>
	<b>3.19</b>	<b>Abnormal screw cap</b>	<b>1</b>
	<b>3.20</b>	<b>“O”ring Φ17x1.8</b>	<b>1</b>
	<b>3.21</b>	<b>Spring cover</b>	<b>1</b>
	<b>3.22</b>	<b>Unloading press spring</b>	<b>1</b>
	<b>3.23</b>	<b>Sealed steel ball</b>	<b>1</b>
	<b>3.24</b>	<b>Unloading valve axle core</b>	<b>1</b>
	<b>3.25</b>	<b>Three-way joint</b>	<b>1</b>
	<b>3.26</b>	<b>Sealed cupreous washer</b>	<b>1</b>

*SPARE PARTS LIST*

No	Name	Quantity	
<b>4</b>	<b>Gear pump assembly</b>		
<b>Gear pump assembly</b>	<b>4.1</b>	<b>M8×80 Inner Six angle bolt</b>	<b>2</b>
	<b>4.2</b>	<b>M8×70 Inner Six angle bolt</b>	<b>2</b>
	<b>4.3</b>	<b>Lower Cover</b>	<b>1</b>
	<b>4.4</b>	<b>Gear base</b>	<b>2</b>
	<b>4.5</b>	<b>Pump</b>	<b>1</b>
	<b>4.6</b>	<b>Initiative gear</b>	<b>1</b>
	<b>4.7</b>	<b>Driven gear</b>	<b>1</b>
	<b>4.8</b>	<b>"O" ring φ28×2.65</b>	<b>1</b>
	<b>4.9</b>	<b>Upper Cover</b>	<b>1</b>
	<b>4.10</b>	<b>Unloading valve axle</b>	<b>1</b>
	<b>4.11</b>	<b>G3/8" × M 18 Straight angle curly head</b>	<b>1</b>
	<b>4.12</b>	<b>Oil seal 10□×18□×4</b>	<b>1</b>
<b>5</b>	<b>Small bending board</b>	<b>1</b>	
<b>6</b>	<b>Connecting Pipe</b>	<b>1</b>	
<b>7</b>	<b>Waist style connecting board</b>	<b>1</b>	
<b>8</b>	<b>Inner six angle bolt M8×15</b>	<b>7</b>	
<b>9</b>	<b>M4×□20 pot head bolt</b>	<b>1</b>	
<b>10</b>	<b>M4 Screw Cap</b>	<b>1</b>	
<b>11</b>	<b>Inner six angle bolt M6×□20</b>	<b>4</b>	
<b>12</b>	<b>M6 stop return Screw Cap</b>	<b>10</b>	
<b>13</b>	<b>M6 Washer</b>	<b>10</b>	
<b>14</b>	<b>Handle</b>	<b>1</b>	
<b>15</b>	<b>U-Style setting horizontal board</b>	<b>1</b>	
<b>16</b>	<b>Connecting bolt M6×□115</b>	<b>4</b>	
<b>17</b>	<b>Operating rod</b>	<b>2</b>	

*SPARE PARTS LIST*

No	Name	Quantity
18	Six angle bolt M8□×45	2
19	Rubber handle	2
20	Nipper	2
21	Side clamp(right)	1
22	Chain rope	1
23	Six angle bolt M8□×25	9
24	M8 Stop return Screw Cap	13
25	M8 Washer	31
26	Handle guard (right)	1
27	Angle fixing board	1
28	Fixing bush	2
29	Dustproof cover	1
30	Supporting bushing	1
31	Square pipe 100×□100(inner)	1
32	Splitter	1
33	M18□×60 Inner Six angle bolt	1
34	M18 Anti retracting Screw Cap	1
35	Handle guard (left)	1
36	Square pipe 120×□120(outer)	1
37	Side clamp(left)	1
38	Differential rubber oil pipe assembly	1
39	Working oil pipe assembly	1
40	Stop φ 20	6
41	Connecting shaft	1
42	Fixing Side board	4

*SPARE PARTS LIST*

No	Name	Quantity
43	Work table	1
44	Small lock plate	6
45	Press board	6
46	Motor installing support stand	1
47	Support stand plate	1
48	Side connecting board for stand	2
49	Oil drain plug M20×1.5	1
50	"O" ring $\phi 18 \times 1.9$	1
51	Bleeding screw	
52	"O" ring $\phi 6 \times 1.9$	
53	Oil pond	1
54	Side connecting board for oil pond	2
55	Oil suction steel pipe assembly	1
56	Oil filter	1
57	Oil circuit steel pipe assembly	1
58	Sealing rubber	2
59	Rubber rolling wheel	2
60	Rolling axle	1